

**Agri-Fab®**

**OWNERS MANUAL**

**MODEL NO.**

**45-02261**



**6 CU. FT.  
POLY LAWN CART**

**CAUTION:**  
Read Rules for  
Safe Operation  
and Instructions  
Carefully

- Safety
- Assembly
- Operation
- Maintenance
- Parts

---

**SpeedPart** *the fastest way to purchase parts* [www.speedepart.com](http://www.speedepart.com)

---

## RULES FOR SAFE OPERATION

Preventing accidents is the responsibility of every equipment operator. The following general safety precautions must be fully understood and followed by every operator.

1. Do not at any time carry passengers in this cart. It is designed for carrying materials only and not intended to carry passengers.
2. Be careful on any grade (hill) and stay off of steep grades.
3. Use caution when loading cart to avoid tipping.
4. Avoid large holes and ditches when transporting loads.

Your Lawn Cart carton contains a hardware package with parts as shown in the chart below and in figure 1.

### Contents of Hardware Pack: (See figure 1)

REF.	QTY.	DESCRIPTION
8	2	U-Clamp
9	4	Carriage Bolt, 5/16-18 x 2-1/2"
10	4	Hex Bolt, 5/16-18 x 3/4"
11	4	Flat Washer, 1.59 O.D.
12	8	Hex Nut, 5/16-18
13	4	Flat Washer, 5/16"
14	8	Lock Washer, 5/16"
15	4	Cotter Pin, 1/8" x 1-1/4"

### HARDWARE REFERENCE CHART

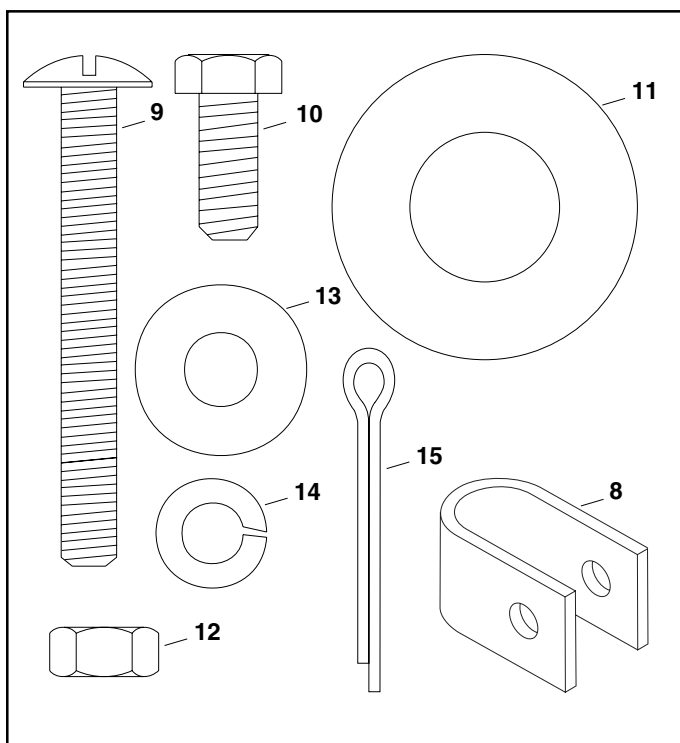

FIGURE 1

## ASSEMBLY INSTRUCTIONS

### TOOLS REQUIRED

- (2) 1/2" Wrench
- (1) Pliers

**NOTE: Do not tighten nuts until entire lawn cart has been assembled.**

1. Refer to parts drawing on page 3 for assembly and reference numbers.
2. Turn the tray (Ref. 1) upside down and support at each end with two boxes or two saw horses.
3. Slide the handle extension (Ref. 5) into ends of upper handle (ref. 4) and align holes.
4. Position handle assembly on tray as shown in parts drawing. Insert one 5/16" x 2-1/2" carriage bolt (Ref. 9) through one of the holes at the rear of the tray and on through the handle assembly.
5. Hold a channel leg (Ref. 6) so that the two holes for the leg brace are toward the rear of the tray. Loosely secure the channel leg (Ref. 6) to the carriage bolt installed in step 4 using one 5/16" flat washer (Ref. 13), 5/16" lock washer (Ref. 14) and 5/16" hex nut (Ref. 12).
6. Repeat step 5 for the other channel leg.
7. Place one U-clamp (Ref. 8) at the end of one handle extension and align holes. Insert a 5/16" x 2-1/2" carriage bolt through a hole at the front of the tray and through the U-clamp, the handle extension and the front hole in the channel leg. Secure loosely with one 5/16" flat washer, 5/16" lock washer and 5/16" hex nut.
8. Repeat step 7 for the other side of tray.
9. Slide axle (Ref. 3) through both U-clamps and center axle left to right.
10. Place a large flat washer (Ref. 11), a wheel (Ref. 2) and another large flat washer onto one end of axle. Assemble two cotter pins (Ref. 15) to axle, securing wheel and washers between them.
11. Repeat step 10 for other end of axle.
12. Attach leg brace (Ref. 7), as shown, to channel legs with four 5/16" x 3/4" hex bolts (Ref. 10), lock washers and hex nuts.
13. Tighten all nuts securely using wrenches.

**MODEL 45-02261 6 CU. FT. POLY LAWN CART**

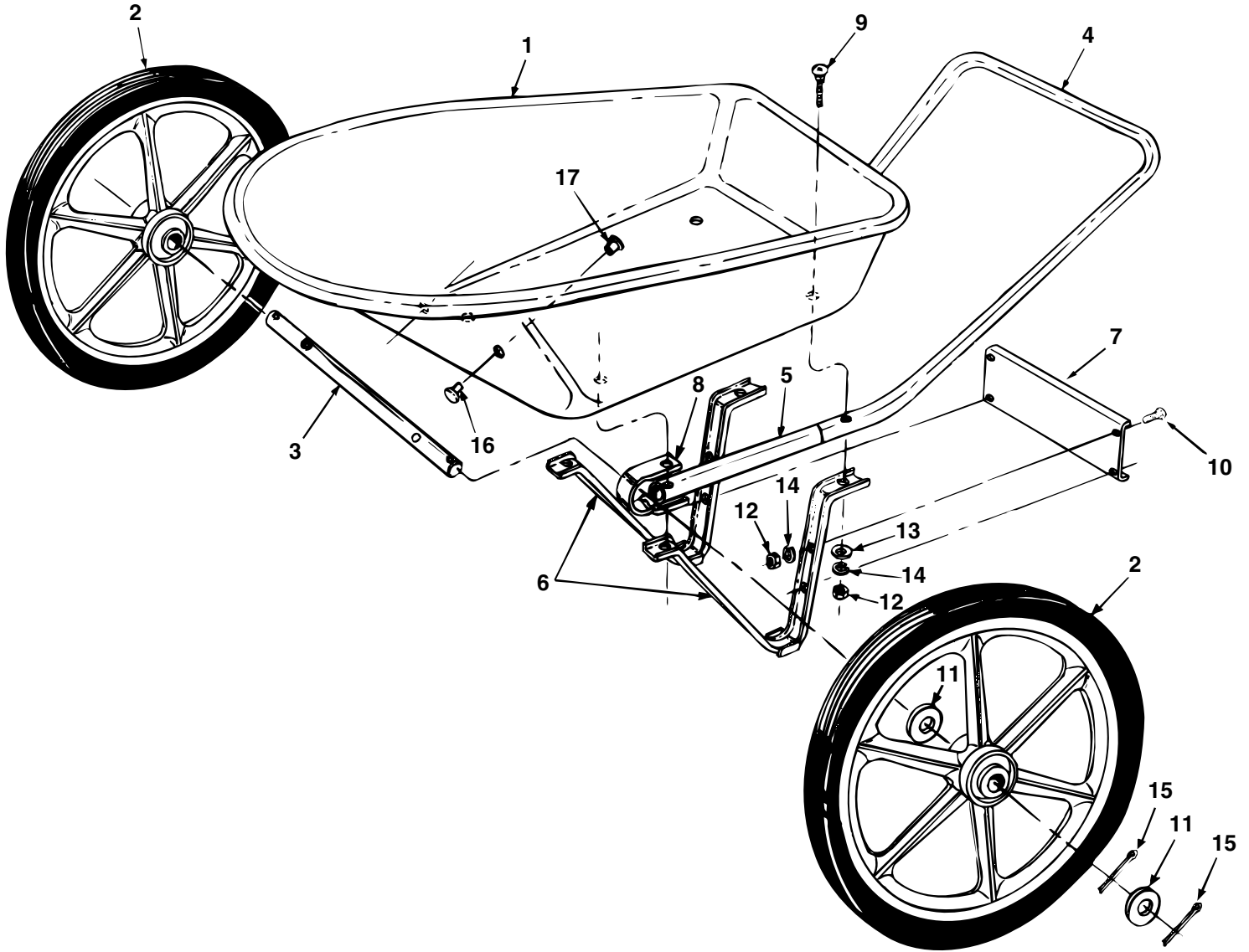

REF. NO.	PART NO.	QTY.	DESCRIPTION	REF. NO.	PART NO.	QTY.	DESCRIPTION
1	44966	1	Poly Tray	10	43182	4	Hex Bolt, 5/16-18 x 3/4"
2	44975	2	Wheel, 20"	11	43009	4	Flat Washer, 1.59 O.D.
3	23877	1	Axle	12	43083	8	Hex Nut, 5/16-18
4	44943	1	Upper Handle	13	43081	4	Flat Washer, 5/16"
5	44944	2	Handle Extension	14	43086	8	Lock Washer, 5/16"
6	44192	2	Channel Leg	15	43010	4	Cotter Pin, 1/8" x 1-1/4"
7	813139	1	Leg Brace	16	45093	2	Ratchet Rivet (Male)
8	23878	2	U-Clamp	17	45094	2	Ratchet Rivet (Female)
9	46324	4	Carriage Bolt, 5/16-18 x 2-1/2"		46827	1	Owner's Manual

\*Purchase Common Hardware Locally.

**SpeedEPart** the fastest way to purchase parts [www.speedepart.com](http://www.speedepart.com)

For Agri Fab Discount Parts Call 606-678-9623 or 606-561-4983

***SpeedPart*** *the fastest way to purchase parts* [www.speedepart.com](http://www.speedepart.com)

**REPAIR PARTS**  
Agri-Fab, Inc.  
303 West Raymond  
Sullivan, IL. 61951  
217-728-8388  
[www.agri-fab.com](http://www.agri-fab.com)

[www.mymowerparts.com](http://www.mymowerparts.com)